



Quick Installations Guide

NSM3000

NSM4000

NSM7000

and

DISC1000

DISC3000

DISC4000

DISC7000

Table of Contents

Table of Contents	3
Copyrights and Trademarks	5
Safety Instructions	8
Setup	13
Checking the Delivery	14
Removing the Transportation Fixtures	15
Mounting the Stands	16
Placing the Optical Library	17
Operation Modes	18
RS232 mode	18
SCSI mode	19
SCSI Cable Requirements	19
SCSI cable length	19
Setting the SCSI ID's for the Drives	20
Connecting to a Host Computer	21
Connecting the serial robotic interface	21
Connecting the SCSI Interface	22
The User Interface	25
The User Interface	26
User Interface Modes	27
Activating the User Interface	28
PIN Codes	28
Enter Admin PIN	28
Enter Service PIN	28
Change Admin PIN	28
Change Service PIN	28
Alarm	29
Mute Alarm Signal	30

Settings	31
Machine Defaults	31
Auto DISC	31
Auto Start	31
Event Logging	32
Event Logging Functions	32
Technical Data	33
NSM3-7000	34
DISC1-7000	35
Slot Upgrade	37
Agency Approvals	38
FCC Declaration	39
Declaration of Conformity NSM3000	40
Declaration of Conformity NSM4000	41
Declaration of Conformity NSM7000	42
Declaration of Conformity DISC1000	43
Declaration of Conformity DISC3000	44
Declaration of Conformity DISC4000	45
Declaration of Conformity DISC7000	46

COPYRIGHTS and TRADEMARKS

- Notice of Copyright
- Disclaimer
- Trademarks
- Contacting DISC

NOTICE OF COPYRIGHT

All rights reserved. Copyright © 2004 by DISC GmbH. No part of this publication may be reproduced, stored in a retrieval system, or traDISCitted in any form or by any means, electronic, mechanical, photocopying, recording or otherwise, without the prior written consent of:

DISC GmbH
Schultheiss-Kollei-Straße 5
D-55411 Bingen
Germany.

Disclaimer

DISC GmbH (DISC GmbH and all of its subsidiaries) takes no responsibility and offers no warranty with respect to the adequacy of this documentation, or the procedures which it describes for any particular purpose, or with respect to its adequacy to produce any particular result. In no event shall DISC GmbH, its employees, its contractors or the authors of this documentation be liable for special, direct, indirect or consequential damages, losses, costs, charges, claims, demands, or claim for lost profits, fees or expenses of any nature or kind.

CHANGES

The following paragraph does not apply where such provisions are inconsistent with local law. Some states do not allow disclaimer of express or implied warranties in certain transactions. Therefore, this statement may not apply to you: The material in this documentation is for information only and is subject to change without notice. While reasonable efforts have been taken in the preparation of this manual to assure its accuracy, DISC GmbH assumes no liability resulting from any errors or omissions in this manual, or from the use of the information contained herein.

DISC GmbH reserves the right to make changes in the product design without reservation and without notification to its users.

Additional Information may be obtained from:

DISC GmbH
Schultheiss-Kollei-Straße 5
55411 Bingen
Germany

TRADEMARKS USED IN THIS MANUAL

DISC, and the DISC logo are registered trademarks of DISC Group

CHAPTER 2: SAFETY INSTRUCTIONS

- Intended Use
- Residual Risks
- Safety

RAPID METHOD

DISCx000: DICC1000
DISC3000
DISC4000
DISC7000

NSMx000: NSM3000
NSM4000
NSM7000

INTENDED USE

The NSMx000 and DISCx000 Optical Libraries are controlled by a host computer or combined server unit (NAS). The Optical Libraries were designed exclusively to read and write bare media, especially the Blue Laser (PDD, PD, BD) media, CD/DVD media and are not intended for any other use.

Improper use of the Optical Libraries may cause residual risks if they are used or operated by unauthorized individuals. Any person who uses the Optical Libraries should read and understand the user's manual and especially the safety instructions.

Residual Risks



Disregarding the safety messages can cause damage to the unit or result in personal injury. Ban of Arbitrary Reversions and Changes The Optical Libraries may not be altered due to applicable safety regulations.

BAN ON ARBITRARY REVERSIONS AND CHANGES

The Optical Library must not be altered or changed in any way that does not comply with applicable safety regulations.

REPAIRS

Repairs must be carried out only by DISC staff, or DISC authorized service providers.

DISC will not be liable for any damage caused from repair by unauthorized individuals. Repair by unauthorized individuals may void your warranty.

Fire Damages

To reduce fire or shock hazard, do not expose the units to rain or moisture.

OPENING THE UNIT

To prevent electrical shock, remove line cord before opening the unit!



Do not leave one of the side walls open while the Optical Library is powered on! Beside danger of injury, incidence of light will disturb the media detection and incoming dust may affect the read/write ability of the media!

SAFETY

This product is in the used way a Laser Class 1 device. Disc access is accomplished via a laser beam. The laser beam does not represent any risk for the user.

This product complies with the DHHS Rules 21 CFR chapter 1, sub chapter J, accession number 9520184, applicable at the date of manufacture.



Caution:



The built in drives become under Laser Class 2M and 3B radiation if they get opened! This includes the risk of injury if you stare into the beam or expose something to the beam. You must not remove and open an optical drive of this Optical Library!

DVD-RAM, DVD-R and Blue Laser Media

These media, specifically DVD RAM and Blue Laser bare media (e.g. BluRay Disc or HD DVD), are very sensitive to scratches and fingerprints. Please handle writeable media with care. Damaged or polluted media might end in a loss of data.

All bare media shall be handled outside of the Optical Library within a certain cover! To export bare media best use the DISC SmartPacks™ (removable front site 15 pcs media magazines).

Even if the used DVD multirecorder drives support several types of DVD recording, only DVD - R ('minus R') general type media are certified for professional data archiving on DVD. CD-R Media

The CD-R drives used in NSM Optical Libraries support 12 X or higher CD recording. Please take care, that the CD-R media you use support your selected recording speed.

To ensure the compatibility of media, DISC recommends to setup the library managing application to use the max. recording speed of
12x for CD-R recording,
8x for DVD-R Disc-at-Once recording,
2x for DVD-R incremental recording
2x for DVD-RAM recording

Professional Disc Media (PDD and BD)

These Blue Laser bare media are very sensitive to scratches and fingerprints. Please handle writeable media with care. Damaged or polluted media might end in a loss of data.

All bare media shall be handled outside of the Optical Library within a certain cover! To export bare media best use the DISC SmartPacks™ (removable front site 15 pcs media magazines).



DISC has qualified only writing and reading of media within the DISC libraries. Externally recorded media have to get tested for functionality. Same is valid for media that are recorded within the DISC libraries and shall get read externally utilizing different systems and drives.

For qualification of certain drive/media compatibilities DISC offers its MediaWatch™ services.

Please ask your sales contact for this DISC service.

Air Filter and Temperature Control

All DISCx000 Optical Libraries are equipped with a fan and an air filter for the cooling air flow and prevention of incoming dust.

Do not cover the air intake grill!

The air filter shall be checked for dust pollution at least once all half year!

If 'Temperature' or 'FAN' alarm ist displayed, please check and if necessary clean or replace the airfilter at the right hand cabinet side!

CHAPTER 4: SETUP

- Checking the Delivery
- Removing the Transportation Fixtures
- Mounting the Stands
- Placing the Optical Library
- Operation Modes
- SCSI CABLE REQUIREMENTS
- Setting the Drive SCSI IDs
- Connecting to a Host Computer
- Connecting Line Voltage

CHECKING THE DELIVERY

Review the following table to ensure that you have all the required equipment.

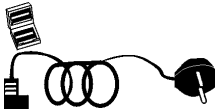

Equipment	Quantity
Power Cord	1 or 2
Power Cord USA (only USA)	1 or 2
Ferrite	1 (2 by dual redundant power supply unit)
RS232 Cable	1
SCSI terminator*	1 per SCSI bus
Quick Installation Guide	1
User Manual CD	1
Allen type screw driver	1
Allen type screws	4-6 (missig screws to fully fix the right side cover)
Stands	4 (only by NSM/DISC 3-7000)
Optical Library	1

* Units that are equipped with LVD SCSI bus technology are internally terminated and therefore shipped without SCSI terminators.

REMOVING THE TRANSPORTATION FIXTURES

▼ Removing the Transportation Fixtures NSM/DISC3-7000

1. Remove the two screws that affix the right cabinet cover of the Optical Library.
2. Remove the right cabinet cover.
3. Remove the transportation fixtures inside the Optical Library.



▼ Removing the Transportation Fixtures DISC1000

1. Remove the 14 screws that affix the right cabinet cover of the Optical Library.
2. Remove the right cabinet cover.
3. Remove the transportation fixtures inside the Optical Library.

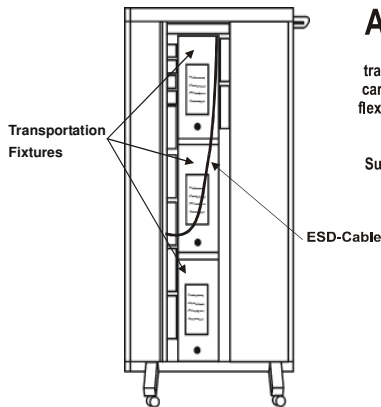

ATTENTION

When removing the transportation lock please carefully protect the black, flexible cable from bending, twisting or other mechanical damage. Such damage may impact the proper function of the library.

A more detailed information how to remove the transportation fixtures can be found directly at the machine.



Powering up the Optical Library with transportation fixtures inside can cause damage to the robotic!



Do not leave one of the side walls open while the Optical Library is powered on ! Besides danger of injury, incidence of light will disturb the media detection!

MOUNTING THE STANDS

For safety reasons, the NSM/DISC 3-7000 Optical Libraries must not be operated without the stands. To mount the stands of the NSM/DISC 3-7000 Optical Libraries two persons are needed.

- Tilt the Optical Library a little bit to the left and push the two stands for the right side into the holes at the bottom of the Optical Library until the stands „click“ in.
- Tilt the Optical Library a little bit to the right and push the two stands for the right side into the holes at the bottom of the Optical Library until the stands „click“ in.

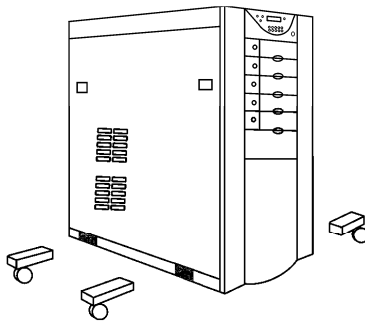

- Take care to mount the stands of the NSM/DISC7000 angled to the right side! The feet have to stand to the outside (see photo):



PLACING THE OPTICAL LIBRARY

The NSMx000 and DISCx000 Optical Libraries are intended for use in office and computer networks.



After delivery the temperature of the Optical Library should be adapted slowly to the temperature of the room before powering up the Optical Library.

Avoid places with

- extreme temperatures or excessive sun exposure
- high humidity
- contact with water or chemicals
- extreme vibrations

The right location

- has a stable, even support
- has sufficient space to pull out the unit
- has at least 10 cm of free space beside each side of the Optical Library
- has sufficient space or possibility to access the air filter module at the right side of the machine

OPERATION MODES

The NSM/DISCx000 Optical Libraries offer several operation modes which can be selected by the mode select switch at the back of the Optical Library. The function of the ID switch depends on the selected mode. Which mode has to be selected depends on the host application which is used to control the robotic of the Optical Library.

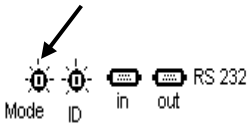

Mode	Function	Function of ID Switch
0	0 RS232 mode	RS232 ID (robotik)
1	SCSI mode	SCSI ID (robotik)
2-F	DISC internal use only	-----

RS232 MODE



The RS 232 mode has to be selected if the robotic of the Optical Library should be controlled via the serial interface (RS 232). The factory default for the RS 232 ID is 00. The ID needs to be changed only, if more than one Optical Library should be connected to the serial bus.



Do not connect more than 3 Optical Libraries to the serial bus. If more than 3 Optical Libraries are connected to the serial bus, the signal might be disturbed.

The maximum cable length of the serial bus must not exceed 15 m.

SCSI MODE



The SCSI mode has to be selected if the Optical Library should be controlled over the SCSI bus. In the SCSI mode the ID switch is used to select the SCSI ID of the Optical Library robotic.

If SCSI mode is selected, the robotic of the Optical Library allocates a SCSI ID on the SCSI bus.

The ID range for the robotic SCSI ID is 0 to 7, default setting is 0.

The SCSI mode must be selected if the Optical Library is controlled via the SCSI bus. The ID switch is used to select the robotics SCSI ID. The range for SCSI IDs is 00 to 07.

SCSI CABLE REQUIREMENTS

The quality of the SCSI cables affects the reliability and usage of a SCSI system. The SCSI - III standard defines the characteristics of good cables. They are 100 % shielded round cables that contain 34 twisted pairs of wires. Each pair should have a characteristic impedance between 90 and 110 ohms. The wire gauge should be 26 or 28. Most SCSI cables do not meet these requirements.

Connector plating, shielding, grounding, strain relief, and the way the wires are routed in the seath all affect the quality of your connection. It is advisable to use only high quality SCSI cables.



Only best shielded 34 pair high quality AWG33 universal LVD SCSI cables that meet the European Directive 2002/EC, Issue 13.02.2003, for RoHS compliance shall be used to connect the DISCx000 robotics and drives!



The max. cable length of the external library – host interconnecting LVD SCSI cable may be 9 meters.

The DISC libraries do have for every internal LVD SCSI bus 1 screw able female 68pin HD connector at the back panel of the machine.



Every library (Optical Library) SCSI bus requires its own HBA channel ! No other external or server-internal devices may be connected to the same bus that is connected to the Optical Library robotic or drives!

SETTING DRIVE SCSI IDS

The ID switches on the rear of the Optical Library are used to set drive SCSI IDs (only NSM/DISC 3-7000).

Use a small screw driver to change the ID setting.

The ID range for each drive is 00 to 07.

For additional information about the drive assignment of the Optical Library see the configuration protocol which is attached to the Quick Installation guide.

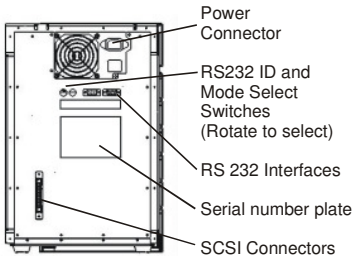
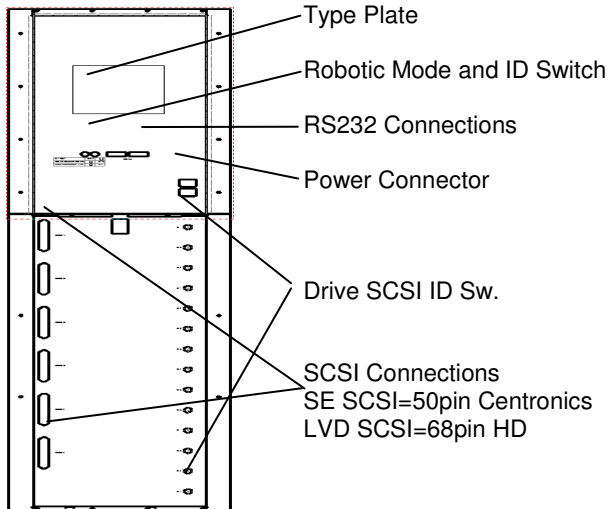

Most Optical Library managing applications require the ascending order of SCSI drive IDs to be set from bottom to top! (D1 = lowest ID, Dn = highest ID)

CONNECTING TO A HOST COMPUTER

CONNECTING THE SERIAL Robotic INTERFACE



Turn off the Optical Library and the host computer when connecting the cables.

Depending on the software which is used to control the robotic of the Optical Library, the serial interface (RS 232) of the Optical Library needs to be connected to the host computer.

Via the RS 232 interface all mechanical operations like loading media, unloading media, importing or exporting media can be controlled. The RS 232 ID for the robotic is set to 00 by factory default. This setting needs to be changed only if more than one Optical Library should be connected to the serial bus.

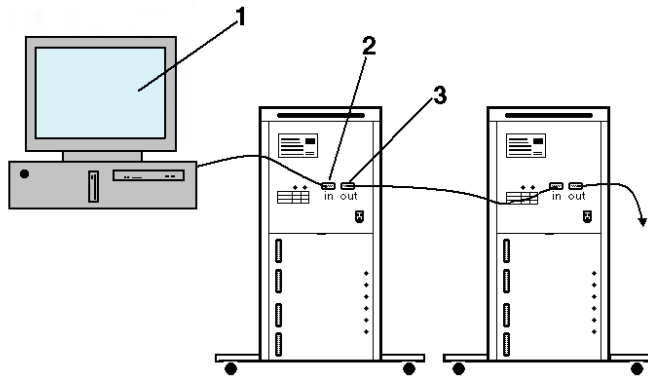

1. Host Computer
2. Connection host computer to RS 232 in
3. Connection of further units to RS 232 out

CONNECTING THE SCSI INTERFACE



Turn off the Optical Library and the host computer when connecting the SCSI cables.



Make sure that all connectors are fixed correctly and tight! Loose contacts will cause serious problems!
After every disconnection of the SCSI cable(s) Optical Library and host computer have to be rebooted!



It is not possible to daisychain the SCSI buses or to connect further external SCSI devices! The LVD bus at the NSM/DISCx000 is internally terminated!

For information about the drive configuration of your Optical Library see the configuration protocol which is attached to the Quick Installation Guide.

If the Optical Library shall be operated in SCSI mode (robotic is controlled via the SCSI bus), the robotic interface is connected to the top SCSI bus (SCSI A).

The NSM3000 and NSM4000 can be equipped with 1 or 2, the NSM6000 and the NSM7000 with up to 3 SCSI busses, depending on the quantity and type of the drives used in the Optical Library. For information about the SCSI buses see the table below.

The DISC3000 and DISC4000 can be equipped with up to 4, the DISC7000 with up to 6 SCSI busses, depending on the quantity and type of the drives used in the Optical Library.

For information about the SCSI buses see the table below.

SCSI 2 (SE) connector layout at NSM3000 and NSM4000

SCSI connector	Layout 1 SCSI bus	Layout 2 SCSI busses
A	bus 1	bus 1
B	not used	bus 1
C	not used	bus 2
D	bus 1	bus 2

SCSI 2 (SE) connector layout at NSM6000 and NSM7000

SCSI connector	Layout 2 SCSI bus	Layout 3 SCSI busses
A	bus 1	bus 1
B	not used	bus 1
C	bus 1	bus 2
D	bus 2	bus 2
E	not used	bus 3
F	bus 2	bus 3

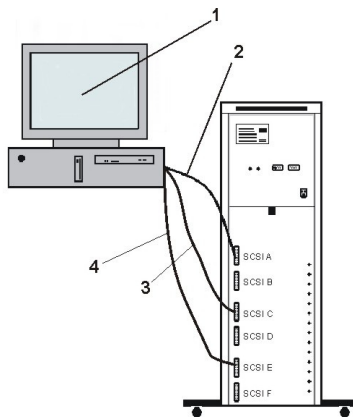

1. Host computer
2. Connection Bus 1
3. Connection Bus 2
4. Connection Bus 3

LVD equipped NSM/DISCx000(U) do have only 1 connector per bus which have to to be connected to 1 HBA channel each!

LVD connector layout at NSM/DISC3000 and NSM/DISC4000

SCSI connector	Layout 1 SCSI bus	Layout 2 SCSI busses
A	bus 1	bus 1
B	not used	not used
C	not used	bus 2
D	not used	not used

LVD connector layout at NSM6000 and NSM/DISC7000

SCSI connector	Layout 2 SCSI bus	Layout 3 SCSI busses
A	bus 1	bus 1
B	not used	not used
C	not used	bus 2
D	bus 2	not used
E	not used	bus 3
F	not used	not used



The tables above are showing the default configurations. If necessary, all DISC3000 and DISC4000 models could have up to 4 and all DISC7000 models up to 6 LVD SCSI busses!

DISC recommends Adaptec AHA39160 dual channel SCSI host adaptors. Ultra 320 SCSI adaptors have to be checked for support of optical devices.

**Bridges to FibreChannel or iSCSI are usable.
DISC recommends the ATTO FC bridges 2390 or 2400 and the ATTO iSCSI bridge 1550.**

*For more information please ask your reseller
or the DISC support under support@disc-gmbh.com*

THE USER INTERFACE

- User Interface Diagram
- User Interface Modes
- Activating the User Interface
- PIN Codes
- Alarm (FAN)
- Settings
- Event Logging

THE USER INTERFACE

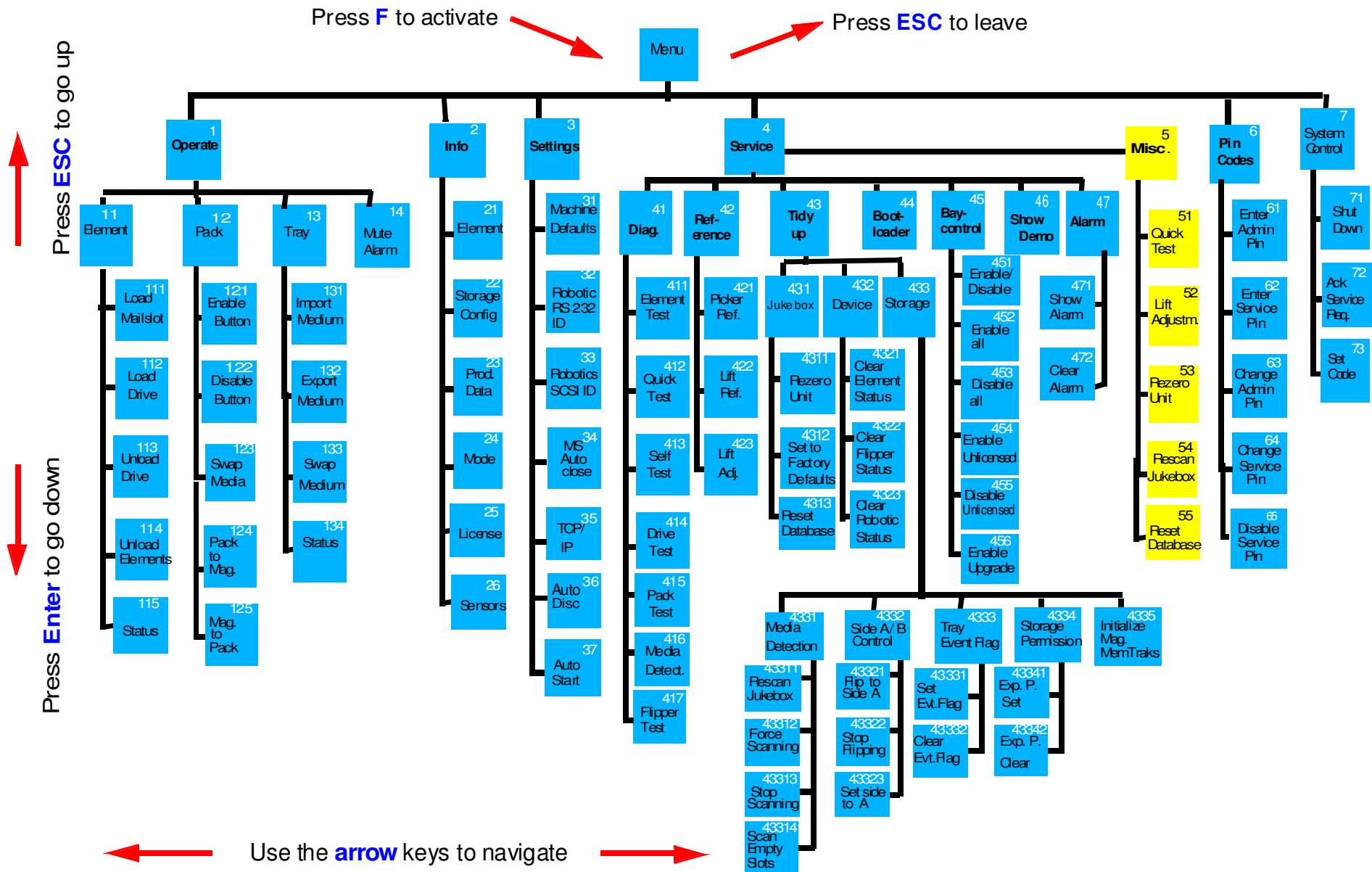

USER INTERFACE MODES



This chapter contains a very basic description of the Optical Library User Interface. For more detailed information see the julebox User Manual.

The User Interface of the NSM/DISCx000 can be used to configure and operate the Optical Library without using a host application. The User Interface has 3 different modes:

USER-MODE

NSM/DISCx000 Vxxxx 01/07/02

User Menu Select Item

In the User Mode only the Info and Pin Codes menu are available. In this mode no settings can be changed or operations performed.

Admin Mode

The Admin Mode can be activated by entering the Admin PIN. In the Admin Mode all necessary settings for installing the Optical Library can be done. In this mode it is also possible to fully operate the Optical Library without using a host application.

Service Mode

The Service Mode can be activated by entering the Service PIN. The functions available in the Service Menu should only be used by trained technicians. Unauthorized use of these functions can cause serious problems and lost of warranty!

The factory default for both PIN Codes is 9999.

The availability of functions in the User mode might change when the Optical Library is controlled by a host application.

ACTIVATING THE USER INTERFACE

The Optical Library User Interface Function Menu is activated by pressing the **F** key. To navigate through the User Interface, use the ← and → buttons for horizontal movement. Use **ENTER** and **ESC** for vertical movement.

To leave the User Interface, go to the menu root (1) and press the 'ESC' key. The Optical Library will leave the User Interface automatically when the Optical Library is not in a submenu where settings can be edited / changed and no button has been pushed for 10 minutes.

PIN CODES

In the **PIN Codes** menu the pin codes can be entered and changed. The factory default for **Admin PIN** and **Service PIN** is **9999**.

Enter ADMIN PIN

After entering the **Admin PIN** and confirming with the 'ENTER' button all functions of the **Operate** menu and the **Settings** menu are available.

Enter Service PIN

After entering the **Service PIN** and confirming with the 'ENTER' button all functions of the User Interface are available. **Only trained technician may use this service menu!**

Change Admin PIN

To change the **Admin PIN**, enter the new **Admin PIN** and confirm with the 'ENTER' button. The **Admin PIN** can only be changed when the original **Admin PIN** has been entered before.

Change Service PIN



To change the **Service PIN**, enter the new **Service PIN** and confirm with the 'ENTER' key. The **Service PIN** can only be changed when the original **Service PIN** has been entered before.

If a PIN is set to 0000, this PIN protection is switched off.

Alarm

The DISCx000 Optical Libraries are equipped with several sensors that cause an alarm signal and / or alarm message to the host application in case of a certain failure.

Following failures may cause an acoustic alarm signal:

- Stopped cabinet cooling fan
- stop of cooling airflow (covered or blocked airfilter)
- overheated drives
- failure of a redundant power supply



When ever a alarm signal is recognized you need to call immediately for service!

The reason for the alarm always is displayed at the front panel display of the Optical Library.

**ALARM
-FAN-**



If 'Temperature' or 'FAN' alarm ist dispayed, please check and if necessary clean the airfilter at the right hand cabinet side!



For check and cleaning of the air filter element, please open the filter grill at the right cabinet side and remove the filter frame.



The fan and the cooling air flow stops if the air filter element is removed. Do not leave the filter element unmounted for longer time (max. 30 minutes)!

Mute Alarm Signal

To stop the acoustic alarm signal you can use function **F14** at the front panel (press the 'F' key followed by '1' and '4')

The Alarm Mute function only will stop the acoustic signal and will neither clear the alarm message nor can clear the alarm event! Blocked airfilters may be cleaned or replaced. **All other alarm events can only get cleared by service interaction! Take care for service as soon as possible after an alarm event has happened!**

Settings

Machine Defaults

The Optical Library **Machine Defaults** are special presets which can be used by a host application to configure the Optical Library. All Optical Libraries are originally set to **Machine Default** No. 21.

A host application might change the **Machine Default** to another value. In the **Machine Defaults** menu, the **Machine Default** can be changed by the user by using the ← and → buttons. The setting can be stored by pressing the **ENTER** key.

In some Machine Defaults the packs can only be controlled by the host software.

If the Optical Library should be operated in SCSI mode, the Machine Default has to be set to 21

Auto Disc

The **Auto Disc** function (**F36**) can be set for one of the media inside the DISC_x000. If the **Auto Disc** function is set, the medium will be moved and loaded to a drive automatically when the Optical Library is powered up. The Auto Disc function can be used to start the complete system from a bootable medium. Parameters for the **Auto Disc** function are the position of the drive (bay) that should be used and the address of the medium (front or rear of Optical Library; bay number; tray number) that should be loaded to the drive.

Auto Start

If the **Auto Start** function (**F37**) is activated, media which are inside drives of the DISC_x000 will be mounted automatically after powering up the Optical Library.

Event Logging

The Optical Library has several counters to log operations and events. None of the event logging functions do affect the operation of the Optical Library. They may be used in every operation mode (User Interface, normal operation mode, Show Demo) of the Optical Library.

Events are created by failures of the Optical Library robotic. Every time an operation (movement) is not finished as expected the event counter of this operation is increased.

If you have trouble with the robotic of a Optical Library please note the event codes before you contact the DISC hotline.

To activate the Event Logging press the **'S' key**, the display shows:

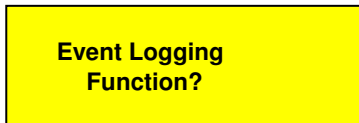

The **keys '1' - '9'** can be used to activate several functions (see table below). To quit the event logging, press the **'S' key again**, the Optical Library will return to the previous shown menu (User Interface menu or normal operation mode).

Event Logging Functions

The following functions are available:

Key	Function
1	Auto event scan
2	Total evebts
3	Event Counter
4	Operation Counter
5	Event Trace Buffer
6	Event Logging Trace Mode
7	Reset all Event Counters
8	Event Logging Robotic State

TECHNICAL DATA

- Technical Data
- Slot Upgrades

TECHNICAL Data NSM3-7000

	NSM3000	NSM4000	NSM7000
Interfaces			
RS232 ID	0	0	0
Baud rate	9600 Baud	9600 Baud	9600 Baud
Number of start bits	1	1	1
Number of data bits	8	8	8
Number of stop bits	1	1	1
Parity check	No parity	No parity	No parity
SCSI Robotic ID	1	1	1
Operating Conditions			
Ambient temperature	10°C – 37°C [50°F – 99°F]	10°C – 37°C [50°F – 99°F]	10°C – 37°C [50°F – 99°F]
Operating temperature	10°C – 33°C [50°F – 91,4°F]	10°C – 33°C [50°F – 91,4°F]	10°C – 33°C [50°F – 91,4°F]
Gradient of temperature	11°C/h [19,8°F/h]	11°C/h [19,8°F/h]	11°C/h [19,8°F/h]
Relative humidity, operating	10% – 68% non condensing	10% – 68% non condensing	10% – 68% non condensing
Power Supply			
Line voltage	90 V – 120 V/4 A 220 V – 240 V/2 A	90 V – 120 V/4 A 220 V – 240 V/2 A	90 V – 120 V/4 A 220 V – 240 V/2 A
Frequency range	50/60 Hz	50/60 Hz	50/60 Hz
Power consumption, normal	140 W	155 W	180 W
Power consumption, max.	220 W	450 W	920 W
Dimensions and Weight			
Width JB / JB incl. Stands	365/620,5 mm	365/620,5 mm	365/835 mm
Height			
Depth	780 mm	980 mm	1500 mm
Weight (without media)	730 mm 54 kg	730 mm 69 kg	730 mm 108 kg

TECHNICAL Data

DISC1-7000

	DISC1000	DISC3000	DISC4000	DISC7000
Interfaces				
RS232 ID	0	0	0	0
Baud rate	9600 Baud	9600 Baud	9600 Baud	9600 Baud
Number of start bits	1	1	1	1
Number of data bits	8	8	8	8
Number of stop bits	1	1	1	1
Parity check	No parity	No parity	No parity	No parity
SCSI Robotic ID	1	1	1	1
Operating Conditions				
Ambient temperature	10°C – 37°C [50°F – 99°F]	10°C – 37°C [50°F – 99°F]	10°C – 37°C [50°F – 99°F]	10°C – 37°C [50°F – 99°F]
Operating temperature	10°C – 33°C [50°F – 91,4°F]	10°C – 33°C [50°F – 91,4°F]	10°C – 33°C [50°F – 91,4°F]	10°C – 33°C [50°F – 91,4°F]
Gradient of temperature	11°C/h [19,8°F/h]	11°C/h [19,8°F/h]	11°C/h [19,8°F/h]	11°C/h [19,8°F/h]
Relative humidity, operating	10% – 68% non condensing	10% – 68% non condensing	10% – 68% non condensing	10% – 68% non condensing
Power Supply				
Line voltage	90 V –120 V/4 A	90 V –120 V/5 A	90 V –120 V/5 A	90 V-120 V/10 A
Frequency range	220 V – 240 V/4 A	220 V – 240 V/4 A	220 V – 240 V/4 A	220 V – 240 V/5 A
Power consumption, normal	50/60 Hz	50/60 Hz	50/60 Hz	50/60 Hz
Power consumption, max.	120 W 220 W	140 W 345 W	180 W 450 W	240 W 920 W

Thermal Emission in BTU	DISC1000	DISC3000	DISC4000	DISC7000
Average	409	478	614	819
Dimensions and Weight	DISC1000	DISC3000	DISC4000	DISC7000
Width JB / JB incl. Stands	300 mm	365/620,5 mm	365/620,5 mm	365/835 mm
Height	410 mm	780 mm	980 mm	1500 mm
Depth	680 mm	730 mm	730 mm	730 mm
Weight (without media)	35 kg	54 kg	72 kg	95 kg
Required floor space	0.25m ²	0.27m ²	0.27m ²	0.27m ²

SLOT UPGRADES

NSM3000 , NSM4000 and NSM7000 Optical Libraries are available in two capacities:

NSM3000U - 145 media slots
NSM3000 - up to 285 media slots

NSM4000U - 145 media slots
NSM4000 - up to 415 media slots

NSM7000U - 510 media slots
NSM7000 - up to 705 media slots

The basic Optical Library is the NSMx000(U) version, the upgrade to full capacity is optional.

DISC DISC1000 , DISC3000 , DISC4000 and DISC7000 Optical Libraries are available in two capacities:

DISC1000U - 45 media slots
DISC1000 - up to 105 media slots

DISC3000U - 145 media slots
DISC3000 - up to 270 media slots

DISC4000U - 145 media slots
DISC4000 - up to 400 media slots

DISC7000U - 510 media slots
DISC7000 - up to 690 media slots

The basic Optical Library is the DISCx000 version, the upgrade to full capacity is optional.

Slot upgrades must be completed in the factory or on site by specially trained service staff. The slot upgrade is not available as a standard field upgrade kit.

For more information about slot upgrades, contact your DISC sales office.

AGENCY APPROVALS

- FCC Declaration
- Declaration of Conformity

AGENCY APPROVALS

FCC DECLARATION

This equipment has been tested and found to comply with the limits for a Class B digital device, pursuant to Part 15 of the FCC Rules. These limits are designed to provide reasonable protection against harmful interference in a residential installation. This equipment generates, uses, and can radiate radio frequency energy and, if not installed and used in accordance with the instructions, may cause harmful interference to radio communications. However, there is no guarantee that interference will not occur in a particular installation. If this equipment does cause harmful interference to radio or television reception, which can be determined by turning the equipment on and off, the user is encouraged to try to correct the interference by one or more of the following measures:

- Reorient or relocate the receiving antenna.
- Increase the separation between the equipment and receiver.
- Connect the equipment into an outlet on a circuit different from that to which the receiver is connected.
- Consult the dealer or an experienced radio/TV technician for help.

Important: This product was FCC verified under test conditions that include the use of shielded cables and connectors between system components. It is important that you use shielded cables and connectors to reduce the possibility of causing interference to radios, televisions, and other electronic devices.

Should you have any problems contact your dealer.

Any change or modifications to the equipment by the user not expressly approved by the grantee or manufacturer could void the user's authority to operate such equipment.

DECLARATION OF CONFORMITY – NSM3000(U)



EG-Konformitätserklärung	EC-Declaration of Conformity	CE-Déclaration de Conformité
<p>mit den Richtlinien 89 / 336 / EWG und 73 / 23 / EWG.</p> <p>Hiermit wird bestätigt, dass das Produkt</p> <p>CD / DVD Optical Library CDC 300 NSM3000</p> <p>mit den folgenden Normen bzw. normativen Dokumenten übereinstimmt:</p> <p>EN 55022: 1998 + A1: 2000 Grenzwerte und Messverfahren für Funkstörungen von informationstechnischen Einrichtungen.</p> <p>EN 50024: 1998 + A1: 2001 Störfestigkeit von informationstechnischen Einrichtungen.</p> <p>EN 61000-3-2: 2000 EN 61000-3-3: 1995 + A1: 2001</p> <p>EN 60950, UL 1950, CUL C22.2No.950 Sicherheit von Einrichtungen der Informationstechnik.</p> <p>Das Qualitätssicherungssystem von DISC garantiert die Konformität.</p> <p>Hersteller:</p> <p>DISC GmbH Im Tiergarten 24 D-55411 Bingen am Rhein</p> <p>Aussteldatum: 02.02.2005</p>	<p>per 89 / 336 / EEC and 73 / 23 / EWG.</p> <p>This is to confirm that the product</p> <p>CD / DVD Optical Library CDC 300 NSM3000</p> <p>is in compliance with the following standards or other normative documents:</p> <p>EN 55022: 1998 + A1: 2000 Limits and methods of radio interference characteristics of information technology equipment.</p> <p>EN 50024: 1998 + A1: 2001 Information technology equipment- Immunity Characteristics- Limits and methods of measurement.</p> <p>EN 61000-3-2: 2000 EN 61000-3-3: 1995 + A1: 2001</p> <p>EN 60950, UL 1950, CUL C22.2No.950 Safety of information technology equipment.</p> <p>DISC quality assurance system assures compliance.</p> <p>Manufacturer:</p> <p>DISC GmbH Im Tiergarten 24 D-55411 Bingen am Rhein</p> <p>Date of issue of the declaration: 02-02-2005</p>	<p>avec 89 / 336 / CEE et 73 / 23 / EWG.</p> <p>Nous déclarons que le produit</p> <p>Optical Library CD / DVD CDC 300 NSM3000</p> <p>est conforme aux normes ou autres documents normatifs suivants:</p> <p>EN 55022: 1998 + A1 2000 Limites et méthodes de mesure des caractéristiques de perturbation radioélectriques produites par les appareils de traitement de l'information.</p> <p>EN 50024: 1998 + A1: 2001 Appareils de traitements l'information - caractéristiques d'immunité - limites et méthodes de mesure.</p> <p>EN 61000-3-2: 2000 EN 61000-3-3: 1995 + A1: 2001</p> <p>EN 60950, UL 1950, CUL C22.2No.950 Sécurité des matériels de traitement de l'information.</p> <p>La système d'assurance de la qualité de DISC garantit la conformité.</p> <p>Fabricant:</p> <p>DISC GmbH Im Tiergarten 24 D-55411 Bingen am Rhein</p> <p>Date d'établissement 7e la declaration: 02.02.2005</p>

W. Beckmann
Managing Director

H. Schellong
Director Development

DECLARATION OF CONFORMITY - NSM4000(U)



EG-Konformitätserklärung	EC-Declaration of Conformity	CE-Déclaration de Conformité
<p>mit den Richtlinien 89 / 336 / EWG und 73 / 23 / EWG.</p> <p>Hiermit wird bestätigt, dass das Produkt</p> <p>CD / DVD Optical Library CDC 400 NSM4000</p> <p>mit den folgenden Normen bzw. normativen Dokumenten übereinstimmt:</p> <p>EN 55022: 1998 + A1: 2000 Grenzwerte und Messverfahren für Funkstörungen von informationstechnischen Einrichtungen.</p> <p>EN 50024: 1998 + A1: 2001 Störfestigkeit von informationstechnischen Einrichtungen.</p> <p>EN 61000-3-2: 2000 EN 61000-3-3: 1995 + A1: 2001</p> <p>EN 60950, UL 1950, CUL C22.2No.950 Sicherheit von Einrichtungen der Informationstechnik.</p> <p>Das Qualitätssicherungssystem von DISC garantiert die Konformität.</p> <p>Hersteller:</p> <p>DISC GmbH Im Tiergarten 24 D-55411 Bingen am Rhein</p> <p>Aussteldatum: 02.02.2005</p>	<p>per 89 / 336 / EEC and 73 / 23 / EWG.</p> <p>This is to confirm that the product</p> <p>CD / DVD Optical Library CDC400 NSM4000</p> <p>is in compliance with the following standards or other normative documents:</p> <p>EN 55022: 1998 + A1: 2000 Limits and methods of radio interference characteristics of information technology equipment.</p> <p>EN 50024: 1998 + A1: 2001 Information technology equipment- Immunity Characteristics- Limits and methods of measurement.</p> <p>EN 61000-3-2: 2000 EN 61000-3-3: 1995 + A1: 2001</p> <p>EN 60950, UL 1950, CUL C22.2No.950 Safety of information technology equipment.</p> <p>DISC quality assurance system assures compliance.</p> <p>Manufacturer:</p> <p>DISC GmbH Im Tiergarten 24 D-55411 Bingen am Rhein</p> <p>Date of issue of the declaration: 02-02-2005</p>	<p>avec 89 / 336 / CEE et 73 / 23 / EWG.</p> <p>Nous déclarons que le produit</p> <p>Optical Library CD / DVD CDC400 NSM4000</p> <p>est conforme aux normes ou autres documents normatifs suivants:</p> <p>EN 55022: 1998 + A1 2000 Limites et méthodes de mesure des caractéristiques de perturbation radioélectriques produites par les appareils de traitement de l'information.</p> <p>EN 50024: 1998 + A1: 2001 Appareils de traitements l'information - caractéristiques d'immunité - limites et méthodes de mesure.</p> <p>EN 61000-3-2: 2000 EN 61000-3-3: 1995 + A1: 2001</p> <p>EN 60950, UL 1950, CUL C22.2No.950 Sécurité des matériels de traitement de l'information.</p> <p>La système d'assurance de la qualité de DISC garantit la conformité.</p> <p>Fabricant:</p> <p>DISC GmbH Im Tiergarten 24 D-55411 Bingen am Rhein</p> <p>Date d'établissement 7e la declaration: 02.02.2005</p>

W. Beckmann
Managing Director

H. Schellong
Director Development

DECLARATION OF CONFORMITY - NSM7000(U)



EG-Konformitätserklärung	EC-Declaration of Conformity	CE-Déclaration de Conformité
<p>mit den Richtlinien 89 / 336 / EWG und 73 / 23 / EWG.</p> <p>Hiermit wird bestätigt, dass das Produkt</p> <p>CD / DVD Optical Library CDC700 NSM7000</p> <p>mit den folgenden Normen bzw. normativen Dokumenten übereinstimmt:</p> <p>EN 55022: 1998 + A1: 2000 Grenzwerte und Messverfahren für Funkstörungen von informationstechnischen Einrichtungen.</p> <p>EN 55024: 1998 + A1: 2001 Störfestigkeit von informationstechnischen Einrichtungen.</p> <p>EN 61000-3-2: 2000 EN 61000-3-3: 1995 + A1: 2001</p> <p>EN 60950, UL 1950, CUL C22.2No.950 Sicherheit von Einrichtungen der Informationstechnik.</p> <p>Das Qualitätssicherungssystem von DISC garantiert die Konformität.</p> <p>Hersteller:</p> <p>DISC GmbH Im Tiergarten 24 D-55411 Bingen am Rhein</p> <p>Aussteldatum: 02.02.2005</p>	<p>per 89 / 336 / EEC and 73 / 23 / EWG.</p> <p>This is to confirm that the product</p> <p>CD / DVD Optical Library CDC700 NSM7000</p> <p>is in compliance with the following standards or other normative documents:</p> <p>EN 55022: 1998 + A1: 2000 Limits and methods of radio interference characteristics of information technology equipment.</p> <p>EN 55024: 1998 + A1: 2001 Information technology equipment-Immunity Characteristics- Limits and methods of measurement.</p> <p>EN 61000-3-2: 2000 EN 61000-3-3: 1995 + A1: 2001</p> <p>EN 60950, UL 1950, CUL C22.2No.950 Safety of information technology equipment.</p> <p>DISC quality assurance system assures compliance.</p> <p>Manufacturer:</p> <p>DISC GmbH Im Tiergarten 24 D-55411 Bingen am Rhein</p> <p>Date of issue of the declaration: 02-02-2005</p>	<p>avec 89 / 336 / CEE et 73 / 23 / EWG.</p> <p>Nous déclarons que le produit</p> <p>Optical Library CD / DVD CDC700 NSM7000</p> <p>est conforme aux normes ou autres documents normatifs suivants:</p> <p>EN 55022: 1998 + A1 2000 Limites et méthodes de mesure des caractéristiques de perturbation radioélectriques produites par les appareils de traitement de l'information.</p> <p>EN 55024: 1998 + A1: 2001 Appareils de traitements l'information - caractéristiques d'immunité - limites et méthodes de mesure.</p> <p>EN 61000-3-2: 2000 EN 61000-3-3: 1995 + A1: 2001</p> <p>EN 60950, UL 1950, CUL C22.2No.950 Sécurité des matériels de traitement de l'information.</p> <p>La système d'assurance de la qualité de DISC garantit la conformité.</p> <p>Fabricant:</p> <p>DISC GmbH Im Tiergarten 24 D-55411 Bingen am Rhein</p> <p>Date d'établissement 7e la declaration: 02.02.2005</p>

W. Beckmann
Managing Director

H. Schellong
Director Development

DECLARATION OF CONFORMITY - DISC1000(U)



EG-Konformitätserklärung	EC-Declaration of Conformity	CE-Déclaration de Conformité
<p>mit den Richtlinien 89 / 336 / EWG und 73 / 23 / EWG.</p> <p>Hiermit wird bestätigt, dass das Produkt</p> <p>PDD Optical Library DISC 1000</p> <p>mit den folgenden Normen bzw. normativen Dokumenten übereinstimmt:</p> <p>EN 55022: 1998 + A1: 2000 Grenzwerte und Messverfahren für Funkstörungen von informationstechnischen Einrichtungen.</p> <p>EN 50024: 1998 + A1: 2001 Störfestigkeit von informationstechnischen Einrichtungen.</p> <p>EN 61000-3-2: 2000 EN 61000-3-3: 1995 + A1: 2001</p> <p>EN 60950, UL 1950, CUL C22.2No.950 Sicherheit von Einrichtungen der Informationstechnik.</p> <p>Das Qualitätssicherungssystem von DISC garantiert die Konformität.</p> <p>Hersteller:</p> <p>DISC GmbH Im Tiergarten 24 D-55411 Bingen am Rhein</p> <p>Ausstellungsdatum: 02.06.2005</p>	<p>per 89 / 336 / EEC and 73 / 23 / EWG.</p> <p>This is to confirm that the product</p> <p>PDD Optical Library DISC 1000</p> <p>is in compliance with the following standards or other normative documents:</p> <p>EN 55022: 1998 + A1: 2000 Limits and methods of radio interference characteristics of information technology equipment.</p> <p>EN 50024: 1998 + A1: 2001 Information technology equipment-Immunity Characteristics- Limits and methods of measurement.</p> <p>EN 61000-3-2: 2000 EN 61000-3-3: 1995 + A1: 2001</p> <p>EN 60950, UL 1950, CUL C22.2No.950 Safety of information technology equipment.</p> <p>DISC quality assurance system assures compliance.</p> <p>Manufacturer:</p> <p>DISC GmbH Im Tiergarten 24 D-55411 Bingen am Rhein</p> <p>Date of issue of the declaration: 02-06-2005</p>	<p>avec 89 / 336 / CEE et 73 / 23 / EWG.</p> <p>Nous déclarons que le produit</p> <p>Optical Library PDD DISC 1000</p> <p>est conforme aux normes ou autres documents normatifs suivants:</p> <p>EN 55022: 1998 + A1 2000 Limites et méthodes de mesure des caractéristiques de perturbation radioélectriques produites par les appareils de traitement de l'information.</p> <p>EN 50024: 1998 + A1: 2001 Appareils de traitements l'information - caractéristiques d'immunité - limites et méthodes de mesure.</p> <p>EN 61000-3-2: 2000 EN 61000-3-3: 1995 + A1: 2001</p> <p>EN 60950, UL 1950, CUL C22.2No.950 Sécurité des matériels de traitement de l'information.</p> <p>La système d'assurance de la qualité de DISC garantit la conformité.</p> <p>Fabricant:</p> <p>DISC GmbH Im Tiergarten 24 D-55411 Bingen am Rhein</p> <p>Date d'établissement 7e la declaration: 02.06.2005</p>

W. Beckmann
Managing Director

H. Schellong
Director Development

DECLARATION OF CONFORMITY - DISC3000(U)



EG-Konformitätserklärung	EC-Declaration of Conformity	CE-Déclaration de Conformité
<p>mit den Richtlinien 89 / 336 / EWG und 73 / 23 / EWG.</p> <p>Hiermit wird bestätigt, dass das Produkt</p> <p>PDD Optical Library DISC 3000</p> <p>mit den folgenden Normen bzw. normativen Dokumenten übereinstimmt:</p> <p>EN 55022: 1998 + A1: 2000 Grenzwerte und Messverfahren für Funkstörungen von informationstechnischen Einrichtungen.</p> <p>EN 50024: 1998 + A1: 2001 Störfestigkeit von informationstechnischen Einrichtungen.</p> <p>EN 61000-3-2: 2000 EN 61000-3-3: 1995 + A1: 2001</p> <p>EN 60950, UL 1950, CUL C22.2No.950 Sicherheit von Einrichtungen der Informationstechnik.</p> <p>Das Qualitätssicherungssystem von DISC garantiert die Konformität.</p> <p>Hersteller:</p> <p>DISC GmbH Im Tiergarten 24 D-55411 Bingen am Rhein</p> <p>Ausstellungsdatum: 02.06.2005</p>	<p>per 89 / 336 / EEC and 73 / 23 / EWG.</p> <p>This is to confirm that the product</p> <p>PDD Optical Library DISC 3000</p> <p>is in compliance with the following standards or other normative documents:</p> <p>EN 55022: 1998 + A1: 2000 Limits and methods of radio interference characteristics of information technology equipment.</p> <p>EN 50024: 1998 + A1: 2001 Information technology equipment-Immunity Characteristics- Limits and methods of measurement.</p> <p>EN 61000-3-2: 2000 EN 61000-3-3: 1995 + A1: 2001</p> <p>EN 60950, UL 1950, CUL C22.2No.950 Safety of information technology equipment.</p> <p>DISC quality assurance system assures compliance.</p> <p>Manufacturer:</p> <p>DISC GmbH Im Tiergarten 24 D-55411 Bingen am Rhein</p> <p>Date of issue of the declaration: 02-06-2005</p>	<p>avec 89 / 336 / CEE et 73 / 23 / EWG.</p> <p>Nous déclarons que le produit</p> <p>Optical Library PDD DISC 3000</p> <p>est conforme aux normes ou autres documents normatifs suivants:</p> <p>EN 55022: 1998 + A1 2000 Limites et méthodes de mesure des caractéristiques de perturbation radioélectriques produites par les appareils de traitement de l'information.</p> <p>EN 50024: 1998 + A1: 2001 Appareils de traitements l'information - caractéristiques d'immunité - limites et méthodes de mesure.</p> <p>EN 61000-3-2: 2000 EN 61000-3-3: 1995 + A1: 2001</p> <p>EN 60950, UL 1950, CUL C22.2No.950 Sécurité des matériels de traitement de l'information.</p> <p>La système d'assurance de la qualité de DISC garantit la conformité.</p> <p>Fabricant:</p> <p>DISC GmbH Im Tiergarten 24 D-55411 Bingen am Rhein</p> <p>Date d'établissement 7e la declaration: 02.06.2005</p>

W. Beckmann
Managing Director

H. Schellong
Director Development

DECLARATION OF CONFORMITY - DISC4000(U)



EG-Konformitätserklärung	EC-Declaration of Conformity	CE-Déclaration de Conformité
<p>mit den Richtlinien 89 / 336 / EWG und 73 / 23 / EWG.</p> <p>Hiermit wird bestätigt, dass das Produkt</p> <p>PDD Optical Library DISC 4000</p> <p>mit den folgenden Normen bzw. normativen Dokumenten übereinstimmt:</p> <p>EN 55022: 1998 + A1: 2000 Grenzwerte und Messverfahren für Funkstörungen von informationstechnischen Einrichtungen.</p> <p>EN 50024: 1998 + A1: 2001 Störfestigkeit von informationstechnischen Einrichtungen.</p> <p>EN 61000-3-2: 2000 EN 61000-3-3: 1995 + A1: 2001</p> <p>EN 60950, UL 1950, CUL C22.2No.950 Sicherheit von Einrichtungen der Informationstechnik.</p> <p>Das Qualitätssicherungssystem von DISC garantiert die Konformität.</p> <p>Hersteller:</p> <p>DISC GmbH Im Tiergarten 24 D-55411 Bingen am Rhein</p> <p>Ausstellungsdatum: 02.06.2005</p>	<p>per 89 / 336 / EEC and 73 / 23 / EWG.</p> <p>This is to confirm that the product</p> <p>PDD Optical Library DISC 4000</p> <p>is in compliance with the following standards or other normative documents:</p> <p>EN 55022: 1998 + A1: 2000 Limits and methods of radio interference characteristics of information technology equipment.</p> <p>EN 50024: 1998 + A1: 2001 Information technology equipment-Immunity Characteristics- Limits and methods of measurement.</p> <p>EN 61000-3-2: 2000 EN 61000-3-3: 1995 + A1: 2001</p> <p>EN 60950, UL 1950, CUL C22.2No.950 Safety of information technology equipment.</p> <p>DISC quality assurance system assures compliance.</p> <p>Manufacturer:</p> <p>DISC GmbH Im Tiergarten 24 D-55411 Bingen am Rhein</p> <p>Date of issue of the declaration: 02-06-2005</p>	<p>avec 89 / 336 / CEE et 73 / 23 / EWG.</p> <p>Nous déclarons que le produit</p> <p>Optical Library PDD DISC 4000</p> <p>est conforme aux normes ou autres documents normatifs suivants:</p> <p>EN 55022: 1998 + A1 2000 Limites et méthodes de mesure des caractéristiques de perturbation radioélectriques produites par les appareils de traitement de l'information.</p> <p>EN 50024: 1998 + A1: 2001 Appareils de traitements l'information - caractéristiques d'immunité - limites et méthodes de mesure.</p> <p>EN 61000-3-2: 2000 EN 61000-3-3: 1995 + A1: 2001</p> <p>EN 60950, UL 1950, CUL C22.2No.950 Sécurité des matériels de traitement de l'information.</p> <p>La système d'assurance de la qualité de DISC garantit la conformité.</p> <p>Fabricant:</p> <p>DISC GmbH Im Tiergarten 24 D-55411 Bingen am Rhein</p> <p>Date d'établissement 7e la declaration: 02.06.2005</p>

W. Beckmann
Managing Director

H. Schellong
Director Development

DECLARATION OF CONFORMITY - DISC7000(U)



EG-Konformitätserklärung	EC-Declaration of Conformity	CE-Déclaration de Conformité
<p>mit den Richtlinien 89 / 336 / EWG und 73 / 23 / EWG.</p> <p>Hiermit wird bestätigt, dass das Produkt</p> <p>PDD Optical Library DISC 7000</p> <p>mit den folgenden Normen bzw. normativen Dokumenten übereinstimmt:</p> <p>EN 55022: 1998 + A1: 2000 Grenzwerte und Messverfahren für Funkstörungen von informationstechnischen Einrichtungen.</p> <p>EN 55024: 1998 + A1: 2001 Störfestigkeit von informationstechnischen Einrichtungen.</p> <p>EN 61000-3-2: 2000 EN 61000-3-3: 1995 + A1: 2001</p> <p>EN 60950, UL 1950, CUL C22.2No.950 Sicherheit von Einrichtungen der Informationstechnik.</p> <p>Das Qualitätssicherungssystem von DISC garantiert die Konformität.</p> <p>Hersteller:</p> <p>DISC GmbH Im Tiergarten 24 D-55411 Bingen am Rhein</p> <p>Ausstellungsdatum: 02.06.2005</p>	<p>per 89 / 336 / EEC and 73 / 23 / EWG.</p> <p>This is to confirm that the product</p> <p>PDD Optical Library DISC 7000</p> <p>is in compliance with the following standards or other normative documents:</p> <p>EN 55022: 1998 + A1: 2000 Limits and methods of radio interference characteristics of information technology equipment.</p> <p>EN 55024: 1998 + A1: 2001 Information technology equipment-Immunity Characteristics- Limits and methods of measurement.</p> <p>EN 61000-3-2: 2000 EN 61000-3-3: 1995 + A1: 2001</p> <p>EN 60950, UL 1950, CUL C22.2No.950 Safety of information technology equipment.</p> <p>DISC quality assurance system assures compliance.</p> <p>Manufacturer:</p> <p>DISC GmbH Im Tiergarten 24 D-55411 Bingen am Rhein</p> <p>Date of issue of the declaration: 02-06-2005</p>	<p>avec 89 / 336 / CEE et 73 / 23 / EWG.</p> <p>Nous déclarons que le produit</p> <p>Optical Library PDD DISC 7000</p> <p>est conforme aux normes ou autres documents normatifs suivants:</p> <p>EN 55022: 1998 + A1 2000 Limites et méthodes de mesure des caractéristiques de perturbation radioélectriques produites par les appareils de traitement de l'information.</p> <p>EN 55024: 1998 + A1: 2001 Appareils de traitements l'information - caractéristiques d'immunité - limites et méthodes de mesure.</p> <p>EN 61000-3-2: 2000 EN 61000-3-3: 1995 + A1: 2001</p> <p>EN 60950, UL 1950, CUL C22.2No.950 Sécurité des matériels de traitement de l'information.</p> <p>La système d'assurance de la qualité de DISC garantit la conformité.</p> <p>Fabricant:</p> <p>DISC GmbH Im Tiergarten 24 D-55411 Bingen am Rhein</p> <p>Date d'établissement 7e la declaration: 02.06.2005</p>

W. Beckmann
Managing Director

H. Schellong
Director Development

